

## HY-AIR

Our HY-AIR is a 3-stage pump designed to reduce cycle time and improve productivity. A compact design with an optional one or two-gallon reservoir alleviates weight restrictions and offers the operator efficient mobility. Simple controls make for short set-up times and the semi-automatic feature allows the operator to experience faster and easier bolting.

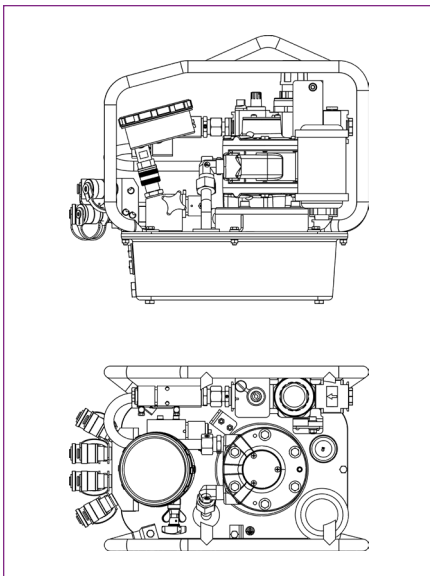

### PUMP SPECIFICATIONS AND FEATURES

<b>Power</b>	3,800 cu.in./sec. (62 l/sec.)
<b>Data Recording</b>	No
<b>Gauge</b>	0-10 k PSI (+/-1% Accuracy)
<b>Reservoir Capacity</b>	1.35 gals. / 5.1 l (2 gals. / 7.6 l tank optional for the HY-115)
<b>Stages</b>	3
<b>Weight</b>	46.3 lbs. / 21 kg
<b>Maximum Oil Flow Rate</b>	770 cu. in./min. (13 l/min.)
<b>Oil Cooler</b>	Yes
<b>Protective Caging</b>	Yes
<b>15' Remote Control</b>	Yes
<b>15' Twin Line Steel Braided Hydraulic Hose</b>	Yes

**HYTORC**

**Headquarters:**  
333 Route 17 N., Mahwah, NJ 07430  
+1-201-512-9500

**Email:**  
info@hytorc.com

**Phone:**  
1-800-FOR-HYTORC

**Online:**  
hytorc.com